

P/N	L/(mm)	T/(mm)
BC-USB-3AB-MM-01	1000	20
BC-USB-3AB-MM-02	1800	30

NOTES:

1. OPEN/SHORT/INTERMITTENCE: 100%.
2. INSULATION RESISTANCE: DC 300V 0.01S 10MΩ Min
3. CONDUCTIVE RESISTANCE: 5 Ω Max
4. RoHS & REACH COMPLIANT

PIN OUT

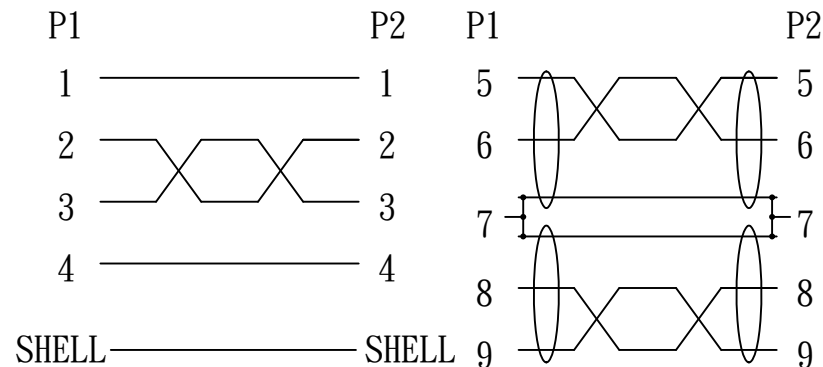

NO.	MATERIAL	DESCRIPTION	QTY.	UNIT
⑤	MOLDED	BLACK PVC		G
④	MOLDED	LDPE		G
③	CONNECTOR	USB3.0 BM, GOLD PLATED PIN, BLUE INSULATION, NICKEL PLATED SHELL	1	PCS
②	CONNECTOR	USB3.0 AM, GOLD PLATED PIN, BLUE INSULATION, NICKEL PLATED SHELL	1	PCS
①	CABLE	(7/0.12TC*1P+D+AM)*2+7/0.12TC*1P+7/0.20TC*2C+ADB PVC/BLACK JACKET OD:5.6±0.2mm MARKING: High Speed USB3.0 Cable AWM STYLE 2725 80°C 30V VW-1	L	MM

Ltemref	Quantity	Title/Name, designation, material, dimension etc			Article NO./Reference	
Designed by FLY	Checkde by HELEN	Approved by - date 2022.12.28	File name	Date 2022.12.28	Scale FREE	
ANGLE:				BC-USB-3AB-MM-0X		
UNIT:MM						